

RADON

A Guide for Canadian Homeowners

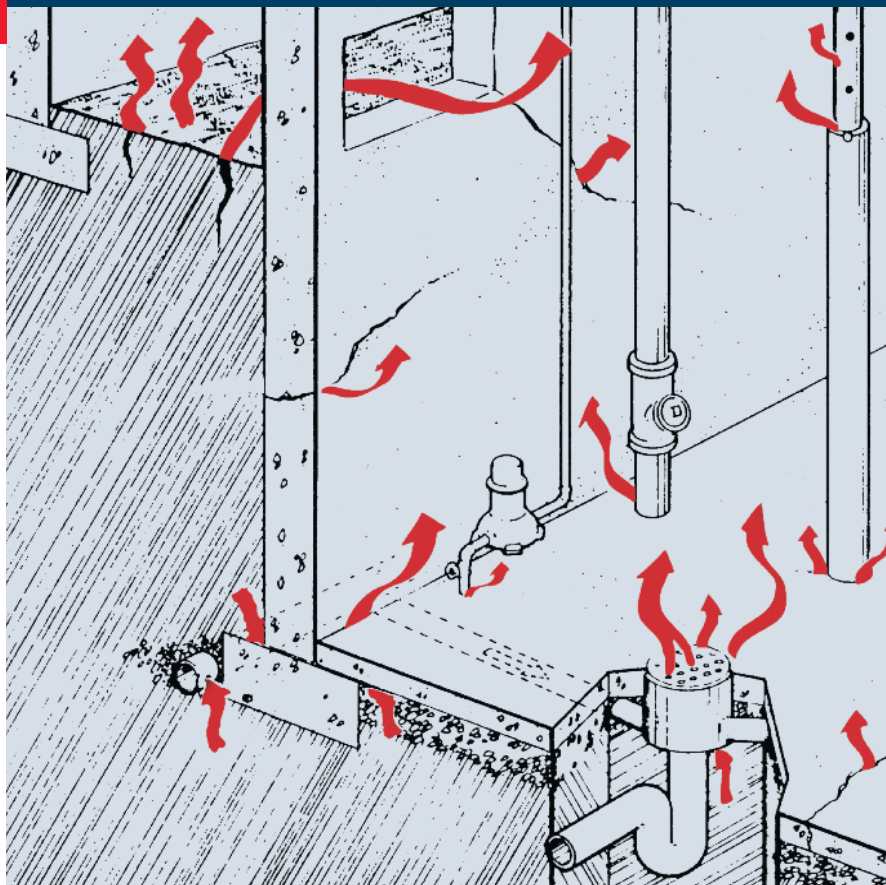



CMHC—HOME TO CANADIANS

Canada Mortgage and Housing Corporation (CMHC) has been Canada's national housing agency for more than 60 years.

Together with other housing stakeholders, we help ensure that the Canadian housing system remains one of the best in the world. We are committed to helping Canadians access a wide choice of quality, environmentally sustainable and affordable homes – homes that will continue to create vibrant and healthy communities and cities across the country.

For more information, visit our website at [**www.cmhc.ca**](http://www.cmhc.ca)

You can also reach us by phone at 1-800-668-2642 or by fax at 1-800-245-9274.

Outside Canada call 613-748-2003 or fax to 613-748-2016.

Canada Mortgage and Housing Corporation supports the Government of Canada policy on access to information for people with disabilities. If you wish to obtain this publication in alternative formats, call 1-800-668-2642.

RADON

A Guide for Canadian Homeowners

Canada Mortgage and Housing Corporation and Health Canada thank the Government of Manitoba for the use of illustrations and text from its publication *Radon: A Guide for Manitoba Homeowners*.

This document presents the best knowledge available at this time. Neither Canada Mortgage and Housing Corporation nor Health Canada assume liability for any damage, injury or expense that may be incurred or suffered as a result of the use of this publication.

Canadian Cataloguing in Publication Data

Main entry under title:

Radon: A Guide for Canadian Homeowners

ISBN 0-662-25909-2

Cat. no. NH15-180/1997E

1. Radon – Toxicology.
 2. Indoor air pollution – Health aspects.
 3. Housing and health.
- I. Canada Mortgage and Housing Corporation

RA1247.R33E32 1997 363.738 C97-980282-2

©1997, 2007, Canada Mortgage and Housing Corporation and Health Canada

Revised: 2003, 2004, 2006, 2007, 2010

Printed in Canada

Produced by CMHC and Health Canada

TABLE OF CONTENTS

INTRODUCTION	1
What is Radon?	1
What is the Risk?	2
What is the Effect of Smoking?	2
A Personal Evaluation of Exposure	3
The Canadian Guideline for Radon	4
How Radon Can Enter Your Home	5
Which Homes Have a Problem?	7
MEASURING RADON LEVELS	9
Methods for Measuring Radon	9
Units of Measure	11
Purchasing Radon Detectors and Measurement Services ..	11
Determining Your Home's Radon Level	12
REDUCING RADON LEVELS	15
Reducing Radon in Existing Homes	15
Preventive Measures for New Homes	24
DEALING WITH CONTRACTORS	31
Finding a Contractor	31
What the Estimate Should Say	32
Signing the Contract	34
Follow-up Measurements	34
QUESTIONS AND ANSWERS	35
POINTS OF CLARIFICATION FOR THE RADON GUIDELINE	39
WHERE TO GET MORE INFORMATION	41
GLOSSARY	47

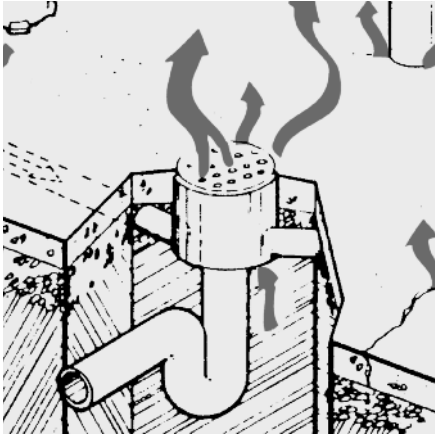

INTRODUCTION

What is Radon?

Radon is a radioactive gas that is colourless, odourless and tasteless. It is formed by the breakdown of uranium, a natural radioactive material found in soil, rock and groundwater.

Radon escapes from the ground into the outdoor air. It is diluted to low concentrations and is not a concern. However, radon that enters an enclosed space, such as a home, can sometimes accumulate to high levels. Radon breaks down to form additional radioactive particles called “progeny” that can contaminate the air you breathe.

Concern in Canada about indoor radon levels began in the mid-1970s. Some homes in communities where uranium ore was either mined or processed were found to have elevated radon concentrations. After this discovery, Health Canada surveyed the radon levels in 14,000 homes in 18 cities across Canada. Also, some smaller communities have been identified by provincial government agencies as having the potential for high radon levels in dwellings.

The majority of homes surveyed showed low concentrations of radon. However, a small but significant minority of homes in some locations were found to have high levels.

What is the Risk?

The only known health risk associated with exposure to radon is an increased risk of developing lung cancer.

Radon gas and radon progeny in the air can be breathed into the lungs where they break down further and emit “alpha particles” (see figure 1). Alpha particles release small bursts of energy which are absorbed by nearby lung tissue. This results in lung cell death or damage.

When lung cells are damaged, they have the potential to result in cancer when they reproduce. Cancers caused by radioactivity are started by chance and not everyone exposed to radon will develop lung cancer. The time between exposure and the onset of the disease is usually many years.

Your risk of developing lung cancer from radon depends on the concentration of radon in the air you breathe and the length of time you are exposed.

Until very recently, the estimate of the risk from radon in homes was uncertain.

However, two recent independent studies in North America and Europe have confirmed that the lung cancer risk extends downward to radon levels as low as 200 Bq/m³. (See Glossary, page 47, for definition.)



Figure 1

What is the Effect of Smoking?

Smoking is the major cause of lung cancer – it is responsible for about 90 per cent of all lung cancer deaths in males and females.

The National Cancer Institute of Canada estimated deaths from lung cancer in 2006 as: 10,700 men and 8,600 women. In 10 per cent of these cases, radon would have caused the lung cancer.

Exposure to radon and tobacco use may combine to increase the risk of lung cancer. Research has compared the cancer rates in smoking and nonsmoking uranium miners. Results indicate that smoking promotes earlier development of lung cancers that may have been caused by radon.

Not smoking is the most effective way you or your family can reduce the risk of lung cancer.

A Personal Evaluation of Exposure

Besides smoking habits, there are other living patterns that could influence your assessment of risk and the need to take action. Consider these questions to help evaluate your personal exposure:

- How much time do your family members spend at home? The guidelines in this booklet assume that 75 per cent of a person's time is spent at home.
- Do you have bedrooms or a home office in your basement? Radon concentrations tend to be greater on the lower levels of a home. A person who sleeps or spends much of his/her waking hours in the basement is exposed to more risk than others who occupy higher levels in the same house.
- How long will you live in your home? The guidelines in this booklet are based on an exposure period of about 70 years. Consider the amount of time you expect to live in your home.

Also consider that taking action to reduce radon in your home may have other benefits:

- Mold and odour problems that can result from moisture and soil gas contaminants entering your home are often reduced by radon reduction work.
- Sealing major cracks, holes and gaps in foundations can reduce cold drafts, lower energy bills and keep insects out.
- Sealing a sump will reduce both radon entry and the risk of injury to small children.

The Canadian Guideline for Radon

There is no regulation in Canada that governs what is deemed to be an acceptable radon level in a home. It is the choice of each homeowner to determine what level of radon exposure they are willing to accept.

Health Canada, in conjunction with the provinces and territories, developed the following guideline to indicate when remedial action should be taken. This guideline was approved by the Federal Provincial Territorial Radiation Protection Committee in October, 2006:

Canadian Radon Guideline

- Remedial measures should be undertaken in a dwelling whenever the average annual radon concentration exceeds 200 Bq/m³ in the normal occupancy area.
- The higher the radon concentration, the sooner remedial measures should be undertaken.
- When remedial action is taken, the radon level should be reduced to a value as low as practicable.
- The construction of new dwellings should employ techniques that will minimize radon entry and facilitate post-construction radon removal, should this subsequently prove necessary

Points of clarification for the guideline are provided on pages 39-40.

The average level of radon in outdoor air is about 10 Bq/m³. However, levels can occasionally reach several times this amount for short periods of time. Indoor radon levels typically range from about 30 to 100 Bq/m³ with an average concentration of 45 Bq/m³. However, in some locations radon can readily exceed 200 Bq/m³, and in a few cases levels have been found as high as 3000 Bq/m³.

Reducing indoor radon levels to be no more than outdoor levels is not yet technologically achievable. However, most homes today can be reduced to 75 Bq/m³ or less.

How Radon Can Enter Your Home

During much of the year, the air pressure inside your home is lower than in the soil surrounding the foundation. This difference in pressures draws air and other gases in the soil, including radon, into the home.

Soil gas containing radon can enter a house any place it finds an opening where the house contacts the soil. These openings can be present even in well-built and new houses.

Potential entry routes for radon in homes with poured concrete foundations include (see figure 2):

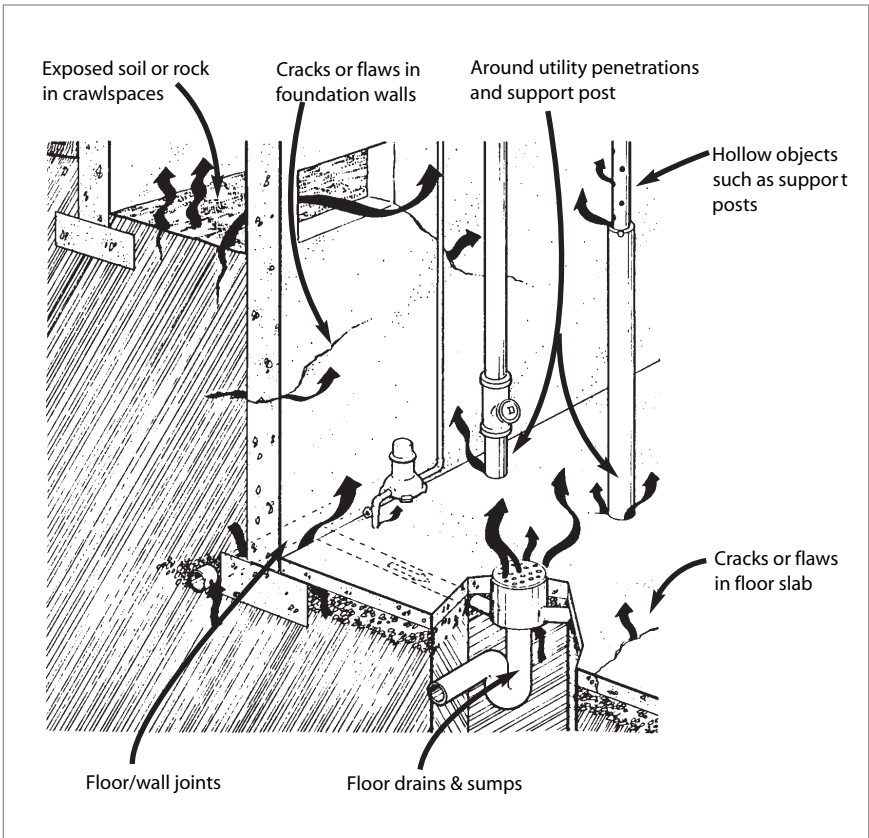

Figure 2: Typical radon entry routes in poured concrete foundation walls and floors

Homes with concrete block foundation walls can have other entry routes (see figure 3) such as:

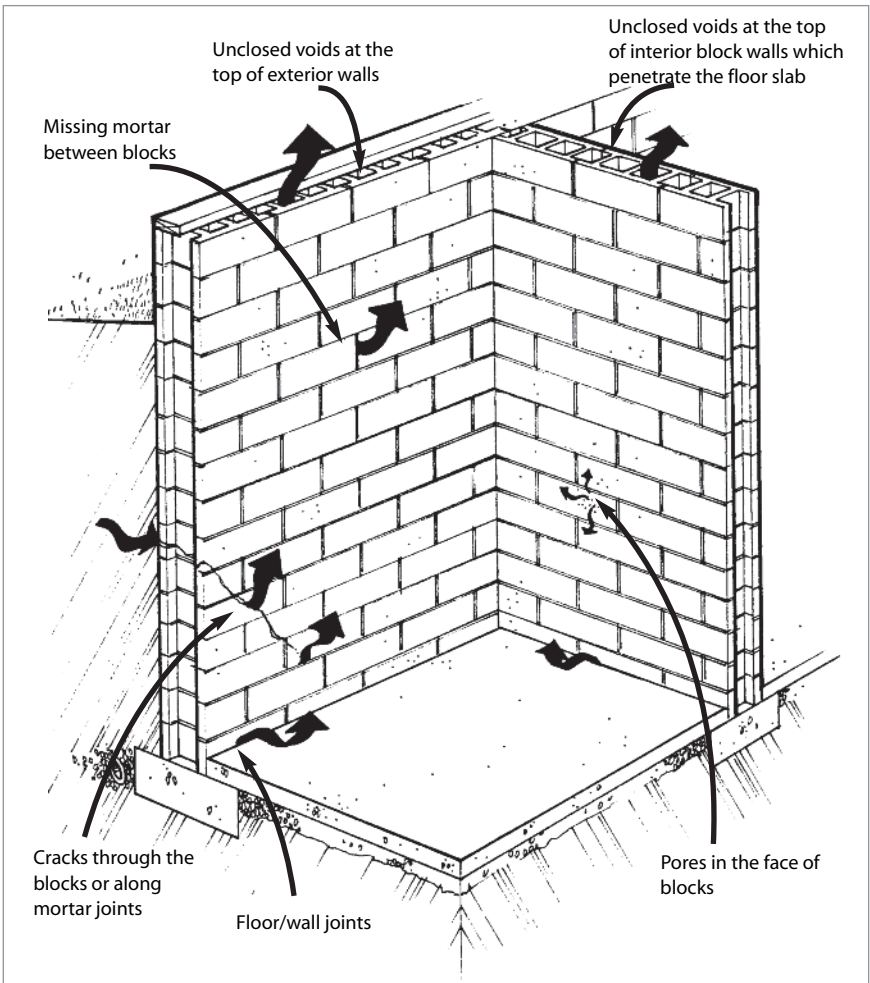

Figure 3: Typical radon entry routes in concrete block foundation walls

Homes with less common types of foundations (e.g., concrete slab-on grade, stone, pressure-treated wood) may have other entry routes where openings or paths exist between the house and the soil. In many homes, regardless of the foundation type, some entry routes will be hidden. For example, they may be concealed by panelling, carpeting, appliances, wood framing or other objects.

In a few areas, large amounts of radon can be found in groundwater from private or small community wells. It can then be released into the air in a home when the water is agitated by activities such as showering, clothes washing or cooking.

Instead of wells, the water supply for larger communities is often drawn from open bodies of water. These sources tend to be low in radon.

Except in a few unusual cases, building materials used to construct a house are not a significant source of radon.

Which Homes Have a Problem?

Almost all homes have some radon. The levels can vary dramatically even between similar homes located next to each other.

The amount of radon in a home will depend on many factors such as:

- **Soil Characteristics** – Radon concentrations can vary enormously depending on the uranium content of the soil. Also, radon flows more easily through some soils than others.
- **Construction Type** – The type of home and its design affect the amount of contact with the soil and the number and size of entry points for radon. It also affects the rate of exchange of outdoor and indoor air.
- **Foundation Condition** – Foundations with numerous cracks and openings have more potential entry points for radon.
- **Occupant Lifestyle** – The use of exhaust fans, windows, fireplaces, etc. influences the pressure difference between the house and the soil that draws radon indoors. These factors also influence the rate of exchange of outdoor and indoor air.
- **Weather** – Variations in weather (e.g., temperature, wind, barometric pressure, precipitation, etc.) can affect the amount of radon that enters a home.

Because there are so many factors, it is very difficult to predict the radon level in a home.

The only way to determine whether your home has high radon levels is to test for it.

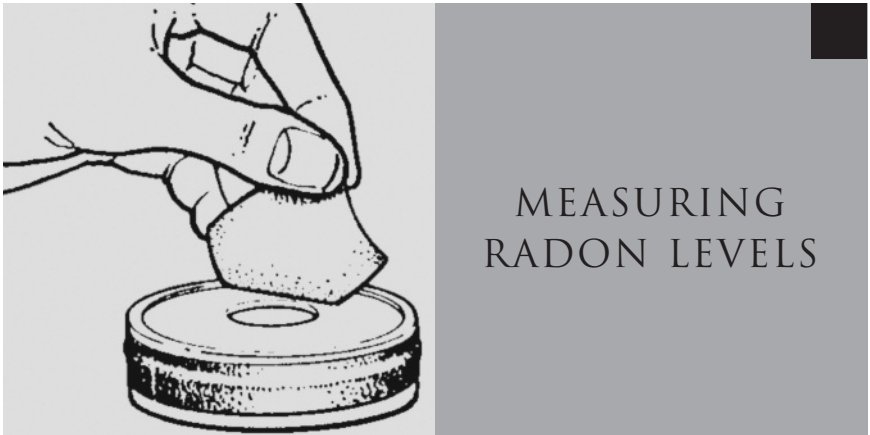

Methods For Measuring Radon

Several methods can be used to measure radon in a home:

- **Charcoal Detectors** – These devices consist of a container filled with charcoal and covered with a screen and filter (*see figure 4*). They are exposed to the air in your home for a specified time period (usually 2 to 7 days), sealed and then sent to a laboratory for analysis.

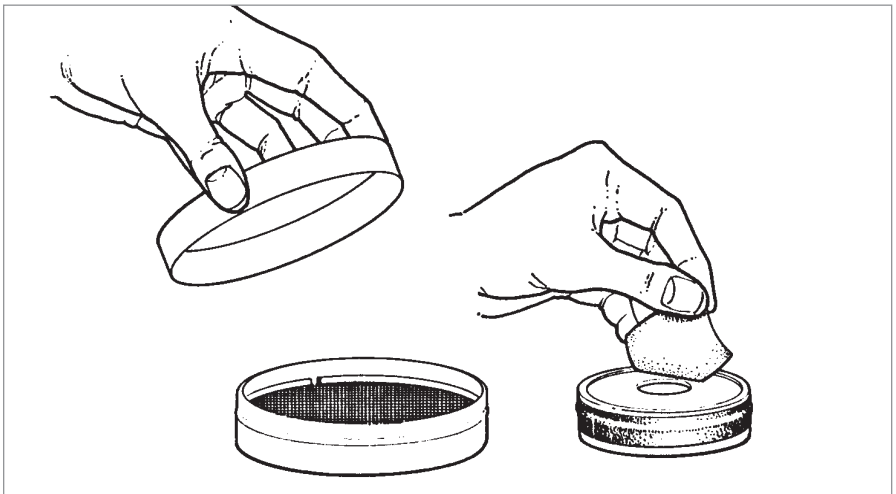

Figure 4: Two types of charcoal detectors

■ **Passive Alpha-Track Detectors** –

These detectors use a small sheet of special film enclosed in a container with a filter-covered opening (*see* figure 5). Passive alpha-track detectors are exposed to the air in a home for a period that can range from several months to one year.

Passive alpha-track detectors must be returned to a laboratory for analysis.

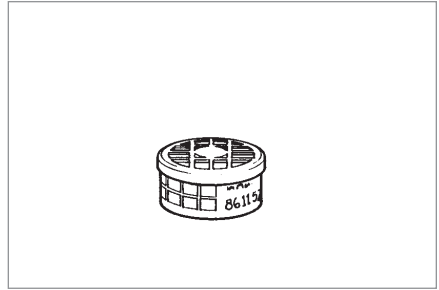

Figure 5: Passive alpha-track detector

■ **Active Alpha-Track Detectors** –

This type of detector is similar to a passive alpha-track detector. However, it offers more accurate measurement by using a small electric air pump (*see* figure 6). Active alpha-track detectors are usually used to measure radon for periods of one week to about two months.

Active alpha-track detectors must be returned to a laboratory for analysis

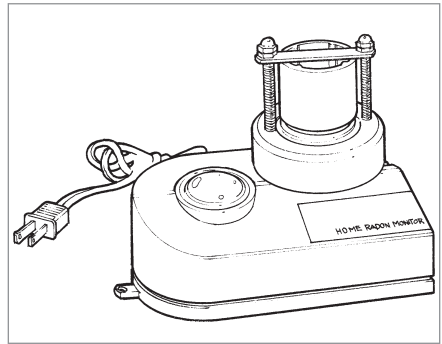

Figure 6: Active alpha-track detector

- **Electret Ion Chamber** – This method uses a special plastic canister that contains a disk called an “electret” with an electrostatic charge (*see* figure 7). It is exposed and the change in the electret’s charge read to determine the radon level. There are two versions, one for short-term tests of a few days or weeks, and one for long-term tests of several weeks or months. Electret ion chambers may be read in the home using a special analysis device or mailed to a lab for analysis.

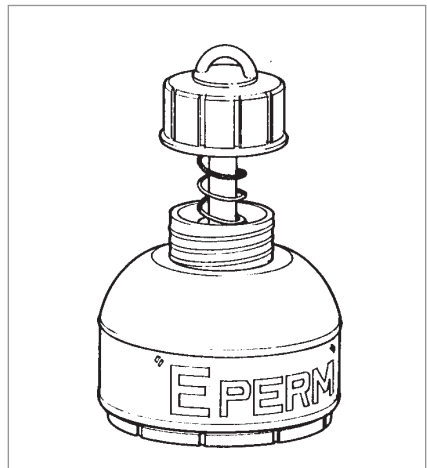

Figure 7: Electret Ion Chamber

- **Continuous Monitors** – These devices typically measure radon over a series of minutes and report the results in hourly increments. Results are normally available in the home. The cost of continuous monitor measurements is generally more expensive than other devices.

Specialized measurement methods not listed above are also available. They require an experienced technician with analytical equipment to visit the house. Because these measurements are expensive, they are not commonly used for initial radon testing in a home. However, they find greater application in follow-up measurements, research work, and to evaluate the success of radon reduction work.

Units of Measure

Your home's measurements will be reported to you in one of three ways. Results from devices that measure concentrations of radon gas are reported as either "Becquerels per cubic metre" (Bq/m³) or "picoCuries per Liter" (pCi/L). Canada and other countries which have adopted the metric system use Bq/m³. One pCi/L equals 37 Bq/m³.

For devices that measure the radiation emitted from radon progeny, the results are reported as "Working Levels" (WL) or milliWorking Levels (mWL). The ratio between radon gas and its radon progeny varies with a number of factors, including the air exchange rate. In most houses, 0.025 WL is approximately equivalent to 200 Bq/m³ (5.4 pCi/L) of radon.

Purchasing Radon Detectors and Measurement Services

Radon detectors and radon measurement services can be difficult to find in many parts of Canada, even in large urban centres.

Charcoal and passive alpha-track devices are available in some retail stores that sell building, hardware or health care products. These detectors are sometimes offered by mail through ads placed in magazines about home improvement or health issues.

Active alpha-track detectors, electret ion chambers and continuous monitor radon measurements may be available from companies in Canada. Contact your provincial or territorial agency (*see* page 42) for suppliers of radon detectors.

Professional home inspectors can be contacted to identify whether local sources exist for radon detection devices and services in your community.

When choosing radon detectors, the lowest price may not be your best choice. The level of service, accuracy of detectors, expertise and advice can vary considerably between different suppliers of radon detectors and measurement services.

For more advice about the availability of radon measurement devices and services in your region, contact your provincial or territorial government (*see* page 42).

At present, Canada does not have a national program for certification of radon testing and mitigation companies, however, development of such a program is currently underway by Health Canada. In the interim, Health Canada recognizes the certification programs offered in the United States through either the National Environmental Health Association or the National Radon Safety Board. Both organizations operate a certification program for individuals who offer radon measurement and mitigation services to the public. The program is designed to provide a list of individuals who have qualified through an educational and examination process to provide high quality radon testing and mitigation services. Periodic performance checks and continuing education requirements must be met in order to maintain the qualification following initial certification. Health Canada encourages Canadians to use an individual or company that participates in one of these certification programs. Information on these certification programs may be found at: <http://www.radongas.org> or <http://www.nrsb.org>.

Determining Your Home's Radon Level

Because radon levels in a home can vary significantly over time, use an extended measurement period, preferably a full year.

While the variation differs from home to home, it is not uncommon to see radon levels in a house change by a factor of two to three or more over a one-day period. Seasonal variations can be even more dramatic with the highest levels usually experienced during winter.

A year-long measurement period will give a much better indication of your exposure than a measurement of shorter duration. Passive alpha track and long-term electret ion chamber detectors are the most practical methods for this type of extended measurement.

When conducting the radon test yourself observe the manufacturer's instructions and the guidelines below when placing a radon detector in your home:

- Make the measurement in the lowest lived-in area of your home, such as the basement, if it is finished.
- Avoid taking measurements in the kitchen. The exhaust fan as well as humidity and airborne particles from cooking may affect the accuracy of some types of radon detectors. Also, avoid bathrooms since relatively little time is spent in this room.
- Place the detector where it will not be disturbed during the measurement period but avoid small enclosed areas, such as a cupboard or closet.
- Do not place the detector close to an outside wall or near a sump or floor drain.
- Avoid locating the detector in drafts from heating or air conditioning vents, near windows or doors, or sources of heat, such as stoves, fireplaces or strong sunlight.
- Place the detector at least 200 mm (8 in.) below the ceiling and 500 mm (20 in.) above the floor.

Compare the results of the year-long measurement of the radon level in your home to *The Canadian Guideline for Radon* on page 4.

Health Canada is now developing standard protocols for radon testing in homes, schools and other large buildings. When completed, these protocols will provide detailed instructions and guidance to radon testing companies and homeowners on how to perform a radon test.

Some people may not want or be able to wait a year for the results. For example, news of high radon levels in your community, renovating a basement as living space, or making an offer-to-purchase on a home may hasten your desire to know whether there is a radon problem. If haste is a priority over accuracy, you can use a charcoal detector. Otherwise, a one-month measurement is the minimum recommended test duration with a one-year test being the optimum. The cost of radon testing is approximately \$50 to \$100.

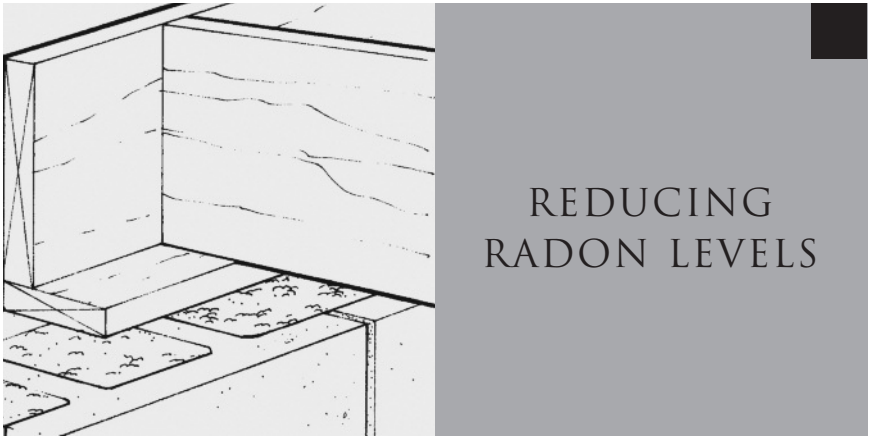

REDUCING RADON LEVELS

Reducing Radon in Existing Homes

This section gives an overview of what can be done to reduce radon levels in existing homes. Health Canada is currently developing standard protocols for the selection, design and operation of systems to reduce radon levels in homes, schools and other large buildings. When completed, these protocols will provide homeowners and mitigation companies with detailed instructions and guidance on radon mitigation techniques. In the interim, comprehensive and technical information may be found in the following U.S. Environmental Protection Agency publications (*see* page 45 for address):

- *Radon Reduction Techniques for Existing Detached Houses – Technical Guidance (Third Edition) for Active Soil Depressurization Systems*

Methods to reduce the level of radon in your home vary considerably in their complexity, long-term effectiveness and cost.

The effectiveness of any one radon reduction method will depend upon the unique characteristics of your home, the level of radon, the routes of the radon entry, and how thoroughly the job is done. A single method may be sufficient, but sometimes several methods must be combined to achieve acceptable results (especially when levels are high).

Many radon reduction measures require installation by a professional contractor or skilled homeowner. However, there are some steps many homeowners can take

immediately, often at little cost. These steps might not always be sufficient by themselves, but they may give some reduction until more comprehensive measures can be implemented.

These steps include:

Close Major Entry Routes for Radon

Many openings in a foundation that may allow radon to enter a home may be small or hidden. However, some openings are large and obvious.

The reduction in radon levels that can be achieved by closing a particular entry route is impossible to predict. However, if a major opening is accessible, it is advisable to close it since some reduction in radon levels may be obtained.

There are also other benefits to closing major entry routes. Molds, odours, insects and cold drafts will find it more difficult to enter the basement. It is also necessary to close major entry routes if an active soil depressurization system is to be installed (*refer to page 19*).

Major openings that can be important to seal include:

- **Open sumps** – Sumps can be fitted with an airtight cover (*see figure 8*). If the sump also acts as a floor drain, add a special trap to the airtight cover and slightly recess the cover into the sump.

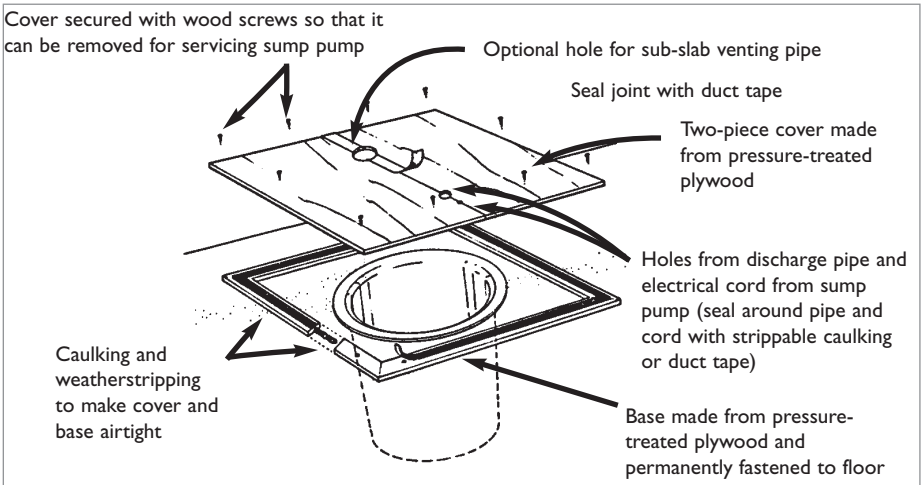

Figure 8: Sealing open sumps

- Floor drains – Basement floor drains can have special traps installed that allow water to drain, but prevent radon from entering the basement (*see* figure 9). These special traps are not a substitute for a sewer backup valve.

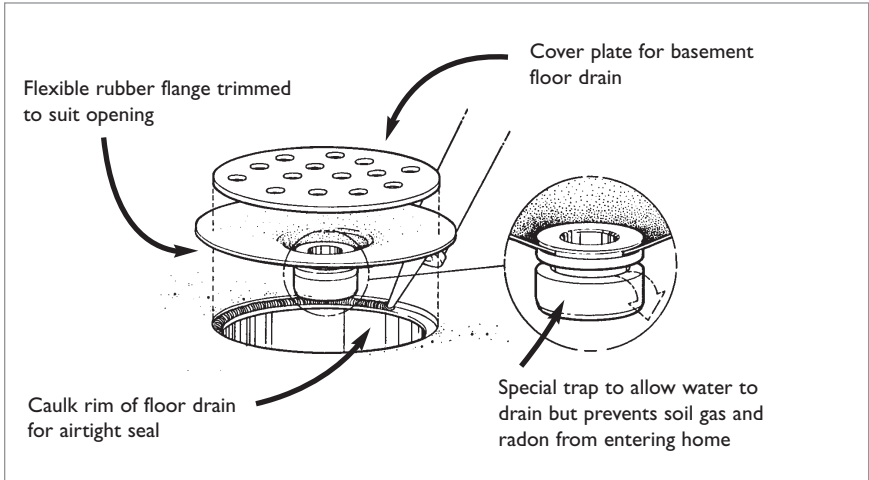

Figure 9: Trap for existing floor drains

- **Exposed soil** – Exposed soil in crawl spaces can be covered by a barrier with sealed edges and joints (*see* figure 17, page 27). If there are major gaps in the basement floor slab (e.g., cold storage room), concrete should be poured to cover any exposed soil.
- **Voids in concrete block walls** – If there isn't a solid row of block, seal voids in the top of foundation and interior load-bearing walls (*see* figure 10).

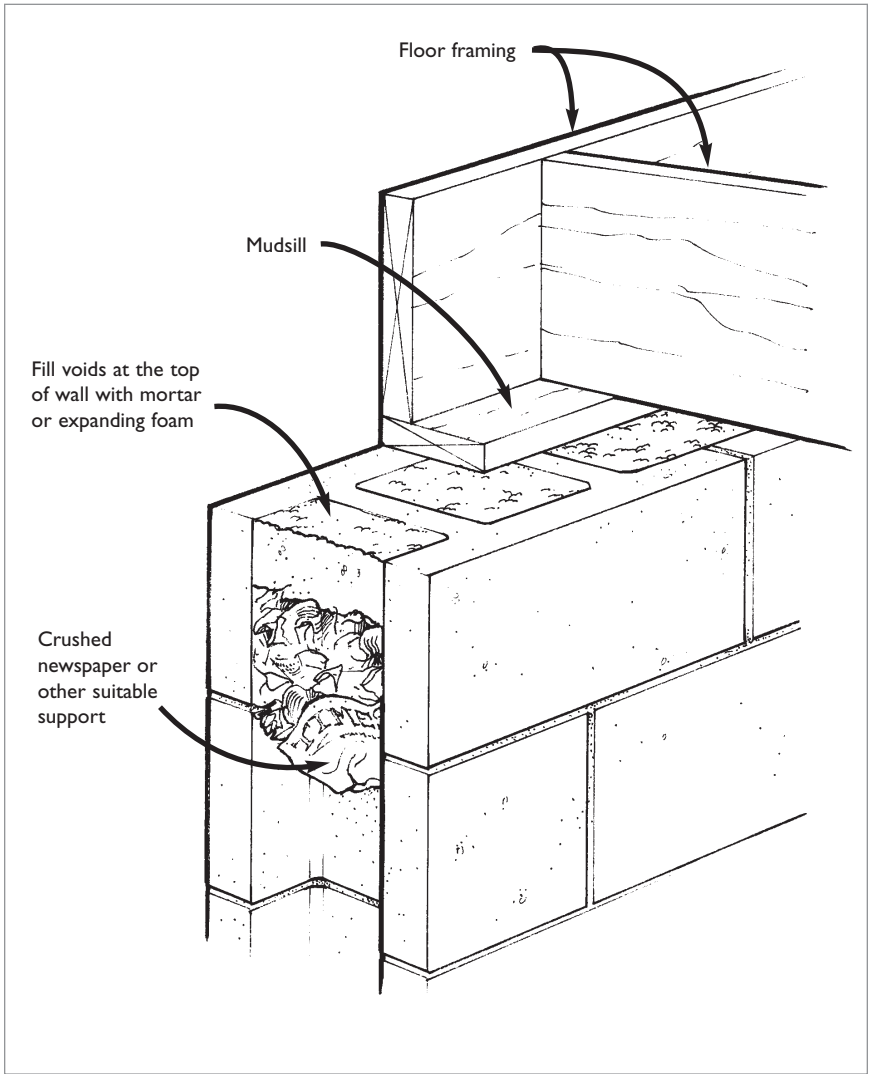

Figure 10: Sealing voids in the top of concrete block walls

Reduce Forces that Draw Radon into the Home

Research has indicated that reducing the negative indoor pressure that draws radon into a home can be an effective measure for some homes. However, there is a need for further research to reduce uncertainties about this technique.

To reduce negative pressure in your home, open a nearby window to provide outdoor air when using an open fireplace. Rarely used fireplaces will not be a factor in radon entry rates. When the fireplace is not in use, make sure the chimney damper is shut. If you require a ventilation system, choose one that is balanced with a supply and exhaust, such as a heat recovery ventilator (HRV) (*see* page 23). Incidental use of exhaust fans (bathroom and kitchen) is acceptable. Avoid continuous use of exhaust fans.

After taking steps to close major entry routes and reduce forces that draw radon into a home, more comprehensive and long-term measures to consider include:

Depressurize the Soil Around the Foundation

Active soil depressurization has been found to be the most effective and reliable radon reduction technique in existing homes. It is also the most common method used by contractors who specialize in radon reduction.

This method involves installing a vent pipe through the basement floor slab (*see* figure 11, page 20) or connecting it to the foundation drain tiles through the sump. A fan that runs continuously is connected to the vent pipe. This reverses the air pressure difference between the house and soil, reducing concentrations of soil gas, including radon, next to the foundation.

The soil in a crawlspace can be vented in a similar manner by installing a sealed polyethylene or comparable membrane over the soil and venting the area beneath the membrane.

For homes with concrete block foundations, it is sometimes necessary to add suction to the block cores. If the block cores are open at the top of the wall, it is important to seal them. This will minimize the amount of heated or cooled air that is removed from the basement.

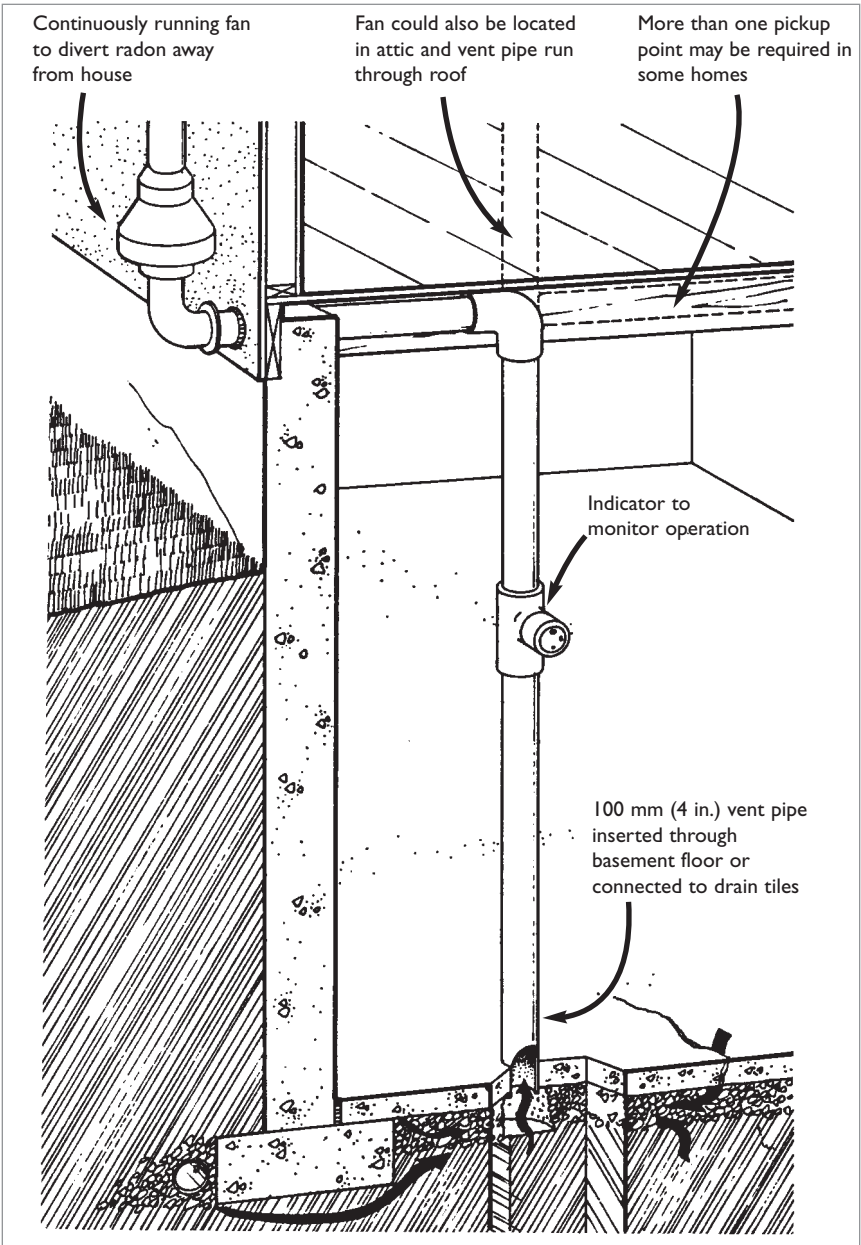

Figure 11: Soil depressurization system

With any active soil depressurization system, it is wise to make sure that operation of the system does not cause backdrafting of combustion appliance (e.g., furnace, boiler, water heater, fireplace, wood stove). Backdrafting occurs when the room in which a combustion appliance is located is depressurized to the extent that combustion products spill into the home instead of venting to the outdoors. Backdraft testing may be done by a trained radon reduction or heating contractor.

The cost of an active (with fan) soil depressurization system ranges from about \$1,500 to \$3,000 including material and labour. There is also an operating cost for electricity for the fan and a modest increase in heating and cooling bills due to increased house ventilation.

When large radon reductions (80 per cent or more) are desired, active soil depressurization is almost always the recommended approach. If smaller reductions are sufficient, the remaining options described in this section may be reasonable alternatives.

Seal any Remaining Entry Routes for Radon

After closing major openings, a further reduction in radon levels can sometimes be achieved by sealing remaining entry routes. Minor cracks in foundation walls and floors can be sealed (*see* figure 12). Larger cracks require special techniques – consult your building material supplier or a contractor.

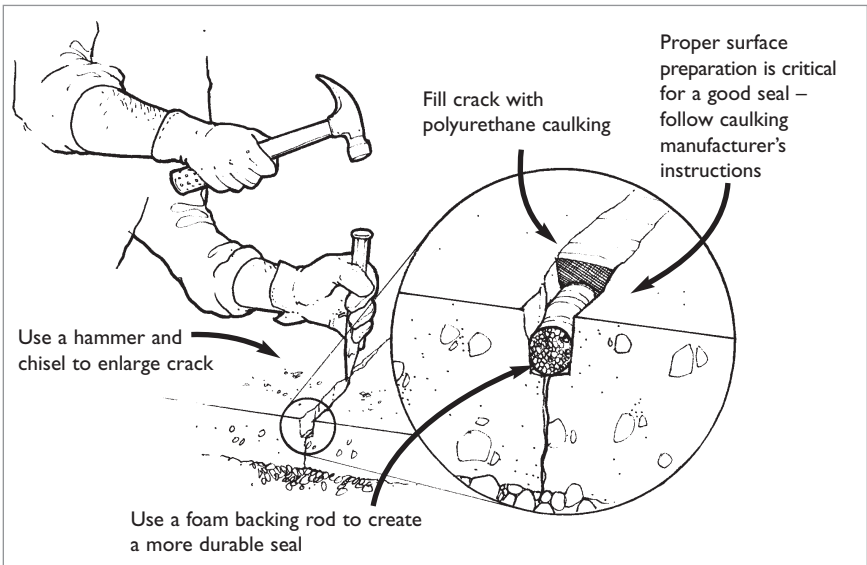

Figure 12: Sealing foundation wall and floor cracks

If accessible, the joint between the foundation wall and basement floor can be sealed (*see* figure 13). The gap around utility penetrations (e.g., water, sewer, electrical, natural gas, fuel oil) in walls and floors can be sealed in a similar manner.

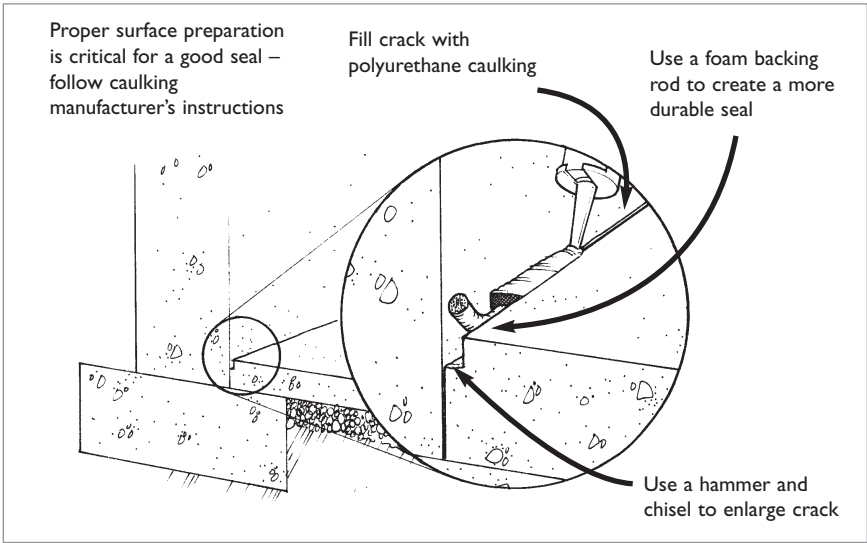

Figure 13: Sealing foundation wall and basement floor joint

Sealing of all entry routes for soil gases such as radon is difficult and challenging. Proper preparation of surfaces to be caulked is extremely important to obtain an effective, long-lasting seal. Entry routes are often numerous – some may be concealed or inaccessible.

Because of these difficulties, when sealing of entry routes is used alone, you should expect only a low to moderate reduction in radon levels. A thorough job of sealing can result in 0 per cent to 50 per cent reduction in radon levels. Sealing will also improve the effectiveness of an active soil depressurization system.

The cost of sealing entry routes is highly variable. It can range from a few hundred dollars to \$2,000 or more. Although the material cost is relatively low, it is very labour-intensive to do a comprehensive job. As the house ages and settles, the seals can deteriorate, and new cracks or entry routes can appear. As a result, there will be an ongoing cost to maintain the seals.

Increase Mechanical Ventilation of the Home

Rather than relying upon natural air movement to remove radon from a home, mechanical ventilation can be used. A system with balanced intake and exhaust air flows is essential so that the house is not depressurized, which may draw in more radon. This can be accomplished by installing a heat recovery ventilator (HRV) (*see figure 14*).

Besides supplying balanced ventilation, a HRV will reduce the energy penalty associated with providing more ventilation to a home.

The suitability of an HRV for radon reduction is limited to situations where only modest reductions are needed. In most homes, an HRV might reduce radon levels by 25 per cent to 75 per cent. HRVs are best suited to homes that are relatively airtight and have other indoor air quality problems such as excessive condensation during winter.

An HRV will cost about \$1,500 to \$2,500 (material and labour). There is also an operating cost for electricity for the HRV's fans as well as an increase in heating and cooling costs due to greater ventilation of the home.

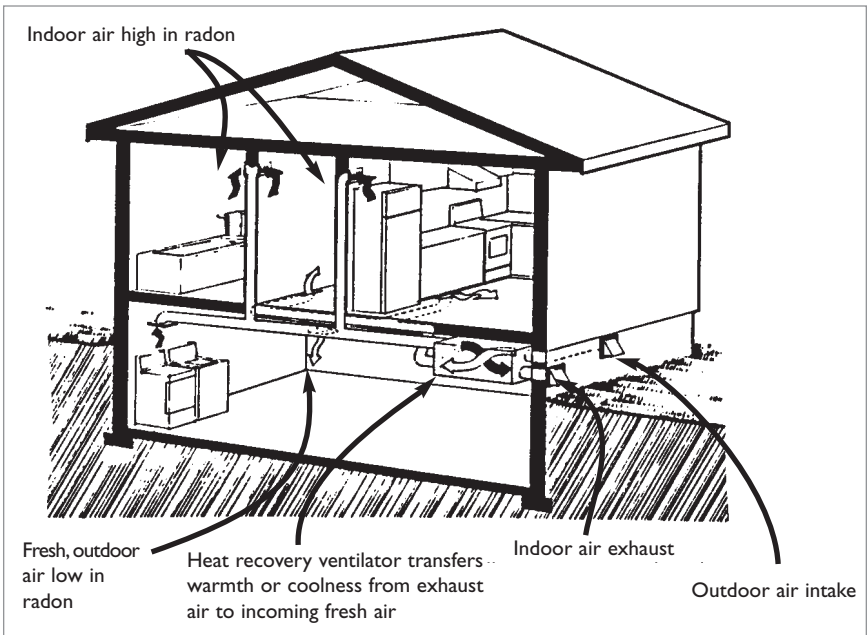

Figure 14: Increasing ventilation with a HRV

Preventive Measures for New Homes

It is very difficult to predict before construction whether a new home will have high radon levels. Fortunately, preventive measures can be taken by your builder during the design and construction process.

Most of these measures are low-cost, desirable for other benefits they provide, and difficult to install after the home is constructed. They include:

- minimizing potential entry routes for radon;
- reducing forces that draw radon into a home; and
- making provision for an active soil depressurization system.

Many elements of these measures are a requirement of the 2005 *National Building Code of Canada* (NBC) issued by the National Research Council of Canada. Check with your builder whether your local authority with jurisdiction for building codes has adopted and enforces the NBC's soil gas control requirements. If not, make sure these measures are included in the plans and specifications for your new home.

Minimize Potential Entry Routes for Radon

The entry routes for radon in new construction are similar to those discussed for existing homes (*see* page 5). Methods your builder can use to reduce entry routes in a new home include:

- Minimize cracking of the basement floor slab by:
 - Properly preparing the sub-slab area (i.e., replace unstable soil, large stones, etc.)
 - Using higher strength concrete. For basement floors, concrete with a 28-day minimum compressive strength of 20 Mpa (3000 psi) is recommended.
 - Using additives in the concrete called “plasticizers” to improve the workability of the concrete. If a plasticizer is not used, there is a likelihood that water will be added on-site to produce more workable concrete. Adding water to the concrete will lower its strength and increase its tendency to crack.

- Providing proper curing conditions. Moistening the slab or coating it with a special compound during curing will result in stronger, more durable concrete. Also if the weather is hot and dry or below freezing, your contractor must take appropriate precautions.
- Use control joints in the concrete floor slab. Since some cracks in the basement slab may be unavoidable, your contractor can direct cracks into controlled locations where they can be sealed with polyurethane caulking (see figure 15). Control joints can be created by:
 - casting plastic special “Ts” into the slab; or
 - using a trowel before the concrete has set; or
 - saw-cutting the slab within one day of its being poured.

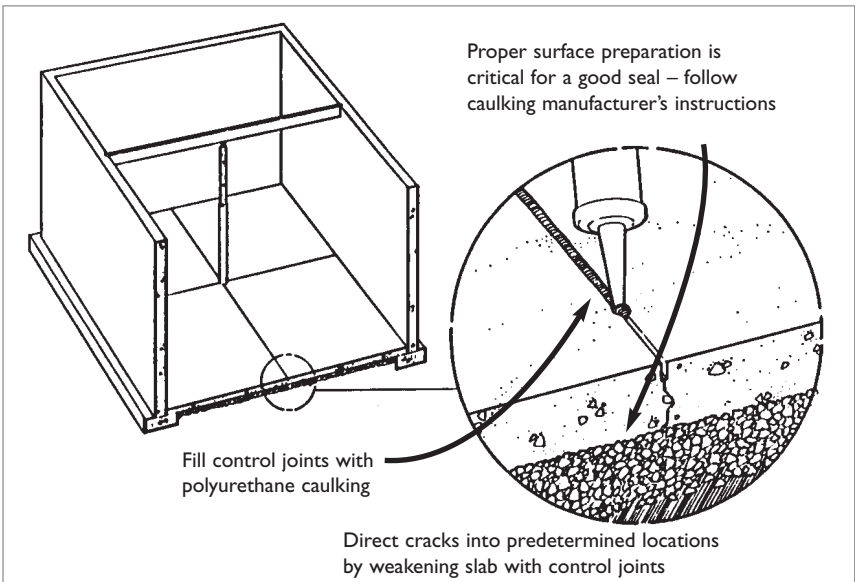

Figure 15: Control joints for new concrete floor slabs

- Seal the basement floor/foundation wall crack. There are several options for sealing this potential radon entry point (see figure 13, page 22 and figure 16, page 26). Note that proper preparation of surfaces to be caulked is critical to obtain an effective, long-lasting seal.

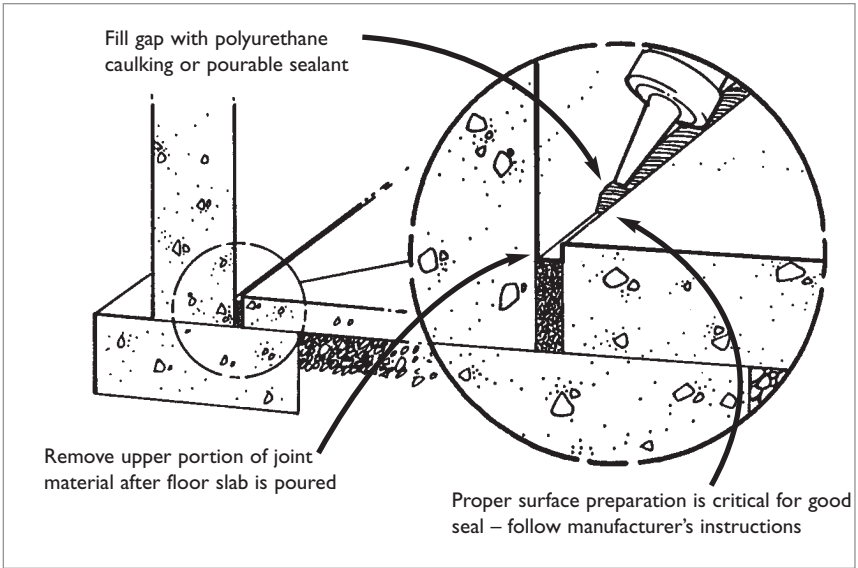

Figure 16: Seal foundation wall and basement floor joint in new construction

- Seal around all penetrations of the foundation walls and basement floors by objects such as utility lines (e.g., water, sewer, electrical, natural gas, fuel oil). The center of hollow objects that penetrate the walls or floors (e.g., metal support posts or masonry for fireplaces) should also be sealed or blocked.
- Install a barrier of at least 0.15 mm (6 mil) polyethylene under the basement floor slab or on top of exposed soil in crawl spaces (*see* figure 17, page 27). Joints in the polyethylene should be overlapped no less than 300 mm (12 in.). In crawlspaces, seal the joints and edges with acoustical sealant. Look for products that are a more durable alternative to regular polyethylene, such as cross-laminated polyethylene.

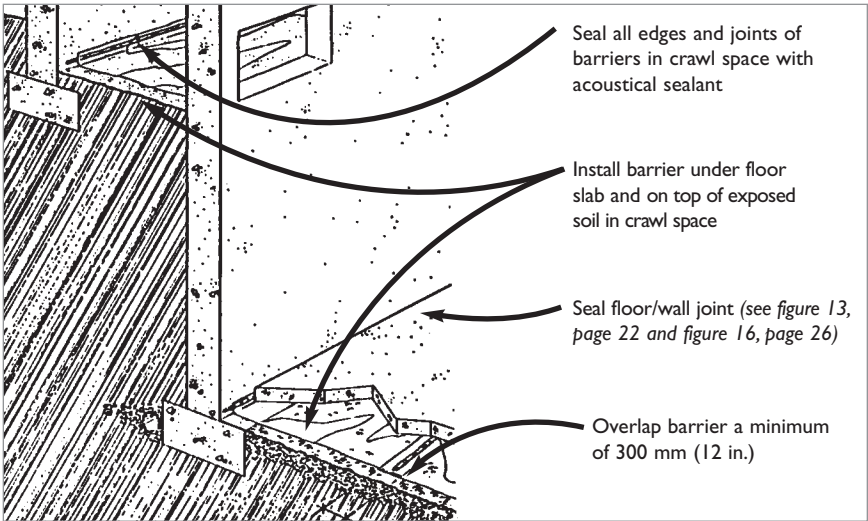

Figure 17: Polyethylene barrier for crawl spaces and basement floor slabs

- Install special traps in floor drains that allow water to drain but prevent radon from entering the basement (see figure 18). These traps have the added benefit of keeping out molds, odours, insects and cold drafts. However, they are not a substitute for a sewer backup valve.

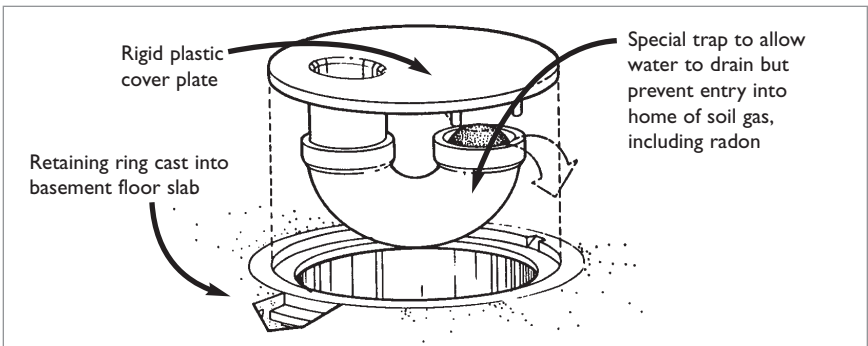

Figure 18: Trap for new floor drains

- Use a sealed lid on the sump. Your builder may either purchase a sealed unit or field fabricate a sealed lid (refer to figure 8, page 16). A sealed lid keeps out radon as well as molds, odours, insects and cold drafts. It also reduces the risk of injury to small children.

- Use a solid course of masonry units at the top and bottom of concrete block foundation walls (*see figure 19*). If regular concrete blocks with voids are used instead, a major entry route for radon may be created.

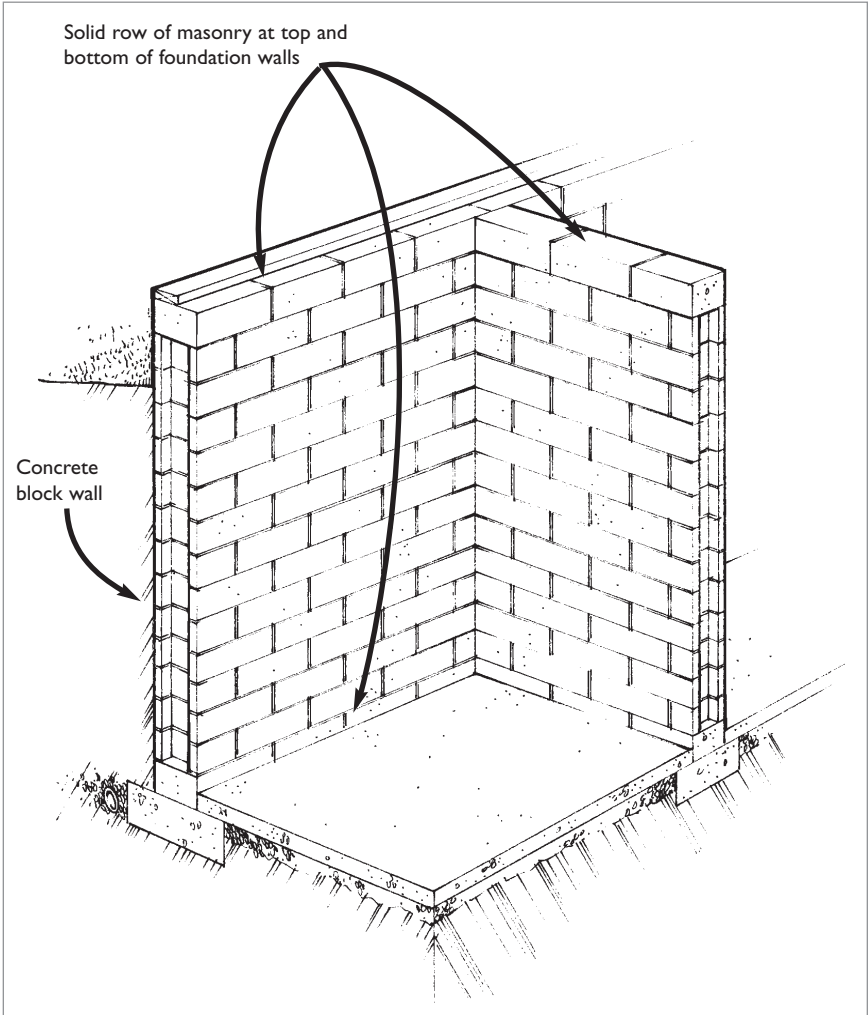

Figure 19: Eliminating voids at the top and bottom of new concrete block foundation walls

Reduce Forces That Draw Radon into a Home

Reducing the pressure difference between the home and soil may reduce the amount of radon drawn indoors. Options include:

- Choose a direct-vent gas or oil furnace, boiler or water heater rather than a conventionally vented unit. Besides reducing the negative pressure in a home, direct-vent combustion appliances reduce energy costs and are less prone to spill combustion products into the home.
- Choose a wood or gas fireplace that is equipped with glass doors that fit tightly, if installing a fireplace. Gas fireplaces should be direct-vent.
- Install a balanced ventilation system, such as a heat recovery ventilator (HRV). A balanced system relies on both supply and exhaust fans to provide ventilation (*see* figure 14, page 23). An HRV will reduce the energy penalty associated with providing more ventilation to a home.
- Never install ducts for a forced-air heating or ventilation system in the basement floor slab. If a crack develops in the slab between the soil and ductwork, radon could be drawn into the home.
- Pay extra attention to ensure that the air barrier (especially between the house and attic) is well-sealed. This will reduce the effects of weather, which can depressurize the home. A well-sealed air barrier will also reduce heating costs and minimize hidden moisture damage to the structure of the home.

Make Provisions for Active Soil Depressurization

The radon prevention methods listed in this section may not always be sufficient to achieve low annual average radon levels – 200 Bq/m³ (5.4 pCi/L) or less. As a result, consider making provisions for an active soil depressurization system (*refer to* page 19). It is more practical and less expensive to install the following components of an active soil depressurization system during, rather than after, construction of your new home.

- Before pouring a slab, ensure that the entire sub-slab area is filled with at least 100 mm (4 in.) of coarse gravel.
- Install a polyethylene air barrier. See directions on page 26.

- A short length of PVC pipe of at least 100 mm (4 in.) diameter should be cast into the floor slab. The pipe should be capped and labeled so that it is not left open.
- After the home is built and occupied, measure the radon levels. If the levels exceed the guidelines given in this booklet, uncap the pipe, install an exhaust fan, and vent to the outdoors. The U.S. EPA recommends exhausting the fan at the roof. The fan should be designed for continuous operation in high humidity environments – in-line fans suitable for radon reduction systems are available from heating, ventilation and air-conditioning wholesalers. This system will ventilate the sub-slab area and should result in significant reduction of the radon levels. Retesting to confirm this is recommended (*see* “Follow-up Measurements” on page 34).

Although it is preferable to locate the fan outside the living space, this may not be practical in very cold climates. An alarm to warn the occupants if the airflow in the system is restricted or blocked is a wise addition. Also, parts of the system which run outside or through unheated attic space will have to be insulated to reduce condensation and blockage by frost or the buildup of ice.

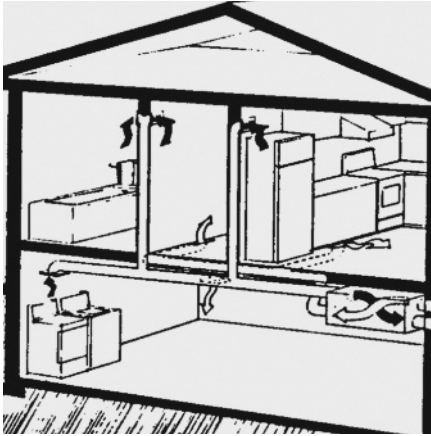

DEALING WITH CONTRACTORS

Finding a Contractor

Many of the techniques used to reduce radon on a long-term basis require the services of a professional contractor. Radon is a relatively new issue. There are not many contractors in most regions of Canada with experience in radon reduction methods.

To find a contractor, ask the company that supplied your radon detector for recommendations. Also ask for recommendations from friends, relatives and neighbours who have recently had work done to their homes.

Try to compile a list of at least two or three contractors and then make inquiries about their reputation. Contact your local Better Business Bureau (BBB). Note that not all contractors are members of the BBB and that membership itself does not necessarily guarantee high quality work. If the contractor is a member, the BBB will advise you of the contractor's "Business Performance Record" according to its record.

Finally, inquire whether the contractor or his staff have received any special training on radon and radon reduction techniques.

As part of its certification program for radon, Health Canada is developing certification requirements for radon mitigation companies. Again, in the interim, Health Canada recognizes the certification programs offered by National Environmental Health Association (NEHA) or the National Radon Safety Board (NRSB). Individuals holding the Residential Mitigation Provider certification from these bodies will have demonstrated knowledge of radon mitigation techniques. This certification is specific for reducing radon in buildings such as homes; however, it does not preclude the ability to apply the skills to larger buildings. Canadian consumers are encouraged to use service providers holding certification. Information on these certification programs may be found at: <http://www.radongas.org> or <http://www.nrsb.org>

For further information on how to deal with a contractor, or to ensure that a company has approved training and experience, contact your provincial or territorial authority for consumer issues.

What the Estimate Should Say

Once you have selected two or three contractors, have them visit your home and review the results of your radon tests. Ask the contractors for a detailed, written proposal on what they suggest to reduce the radon levels in your home.

Before providing you with an estimate, a good contractor will give the area to be worked on a thorough examination. Accompany them on the tour. Watch for the contractor's attention to detail and do not be afraid to ask questions related to the material and installation procedures. Consider the following when evaluating the contractor:

- How many homes has the contractor worked on to reduce radon levels? Were any of the homes similar to yours? What were the radon levels before and after their work? Were the reductions in radon levels measured independently?
- Can the contractor supply referrals? This may be difficult because most homeowners consider the radon reductions work done by the contractor for them to be confidential. However, a contractor who has done work on a large number of houses should have a few clients willing to act as referrals.

- Is the contractor able to clearly explain the proposed work? If the contractor's proposal differs from the recommendations given in this booklet, are the reasons given clear? Does the proposed design include features that would warn you if the reduction system were to malfunction?

Important information that should appear in the contractor's written estimate includes:

- the name, address and telephone number of the contractor;
- the cost and details of material (including quantity, size, capacity, brand name, style, colour, etc.);
- the cost of labour;
- the total cost of the job, including all applicable taxes and permit fees;
- the estimated starting date and completion date for the work;
- a statement that liability insurance and applicable workers' compensation coverage is carried by the contractor to protect you in the event of injury to persons or damage to property while the work is being carried out;
- responsibility placed on the contractor for patching holes, cleanup after the job and incidental damage;
- details of warranties or guarantees; and
- a description of what the homeowner is expected to do (e.g., make the work area accessible).

When evaluating proposals from contractors, the lowest estimate may not be your best choice. Make sure that the various bids cover the same work. If the proposed work differs, ask the contractors to explain why.

An unusually low bid may simply mean that the contractor has made a mistake or does not know enough about the work to estimate properly. In these cases, the contractor may cut corners or add unjustified extras to the bill to avoid losing money. In extreme cases, the contractor may simply abandon the job.

Signing the Contract

The next step is to ask the contractor you have chosen to prepare a contract based on their proposal.

Do not sign the contract until you have read it carefully. Never sign an incomplete contract. Check all standard terms and conditions – read the fine print. Make sure everything in the contract matches the original proposal.

In some provinces or territories, you may be able to change your mind and cancel a contract within a specified time limit if you signed an agreement with a door-to-door salesperson. For information about your cancellation rights and responsibilities, contact your provincial or territorial authority for consumer issues.

Follow-up Measurements

After taking action to reduce radon levels, conduct a follow-up measurement, using the procedures described on page 12. It is best to measure for a least one month in the heating season, when windows are closed

When doing follow-up measurement, deal with a testing company that has no affiliation with the contractor who performed the radon reduction work. This eliminates a potential conflict of interest and will give you more confidence in the test results.

After these initial measurements are completed, consider making further long-term measurements on a regular basis. This will enable you to monitor whether the performance of the radon reduction work is maintained over the years.

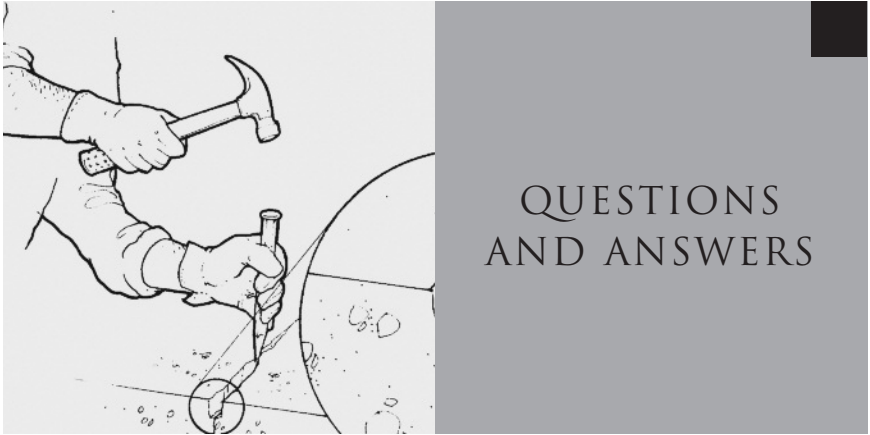

The following are frequently asked questions about radon and their answers:

Q. We occasionally notice an unusual smell in our basement. Could it be due to radon?

A. No. Radon has no odour.

Q. Food items that we have stored in the basement have spoiled. Is radon the cause?

A. No. Radon is chemically inert and cannot react with things and spoil them.

Q. Shortly after moving into our home, several members of our family developed persistent coughs. Could radon be the reason?

A. No. Exposure to radon is not associated with persistent coughs.

Q. I have recently developed headaches which my doctor cannot explain. Could radon be the cause?

A. No. The only known health effect from radon is an increased risk of developing lung cancer.

Q. Should I be concerned about radon in my children's school or my workplace?

A. There has been only limited testing for radon in schools and workplaces in most regions of Canada. Preliminary studies suggest that schools and large public buildings usually have lower radon levels than homes in the same community. However, the only sure way to know whether a school or workplace has elevated radon levels is to test.

Q. Is radon more of a problem in older or newer homes?

A. The age of a home has not been found to be a reliable indicator of whether it will have high radon levels.

Q. My neighbour's house was tested and had high radon levels. Does this mean that the radon levels in my home will also be high?

A. Not necessarily. Radon levels can vary significantly even in similar homes that are built close to one another. You should test your home to be sure of its radon level.

Q. My house has high radon levels. Can it be fixed? How much will it cost?

A. Virtually all homes can have their radon levels significantly lowered. Although costs can vary considerably, experience has shown that reducing radon in most homes can cost from a few hundred dollars to about \$3,000.

Q. I intend to purchase (or sell) a house, what are my options regarding radon testing?

A. Your choices include:

- Disregard or ignore any potential problem.
- When listing the home for sale, the seller could indicate to their broker whether the home has been tested for radon and, if it has, what the test results were.

- The purchaser could make the offer conditional on testing by an approved contractor to indicate whether the radon levels are acceptable (the purchaser would pay for the testing). If the levels are too high, the offer becomes null and void.
- The purchaser could make an offer that includes a holdback of a specified amount of money pending test results. If the test results are above an acceptable level, the holdback can be used to compensate the purchaser for expenses to reduce the radon levels.
- The purchaser could make an offer lower than would be normal because of high test results.

Each of the above approaches has potential advantages and disadvantages. Consult your realtor and lawyer for specific advice.

Q. I am going to build a new home. Can the soil be tested for radon before construction?

- A.** The radon concentration in the soil can be measured. Unfortunately, these tests can be expensive and with present technology are not a reliable predictor of what the radon levels will be in a new house. Have the builder install the inexpensive measures described on pages 29-30. If you want to vertically vent the sub-slab fan, have a vertical PVC pipe installed inside the walls to the top floor ceiling and terminate it, with a cap, in the attic.

Q. Should I test our water supply for radon?

- A.** You should always test the air in your home first. If the radon levels are high and you use water from a well, a radon test of the water may be worthwhile.

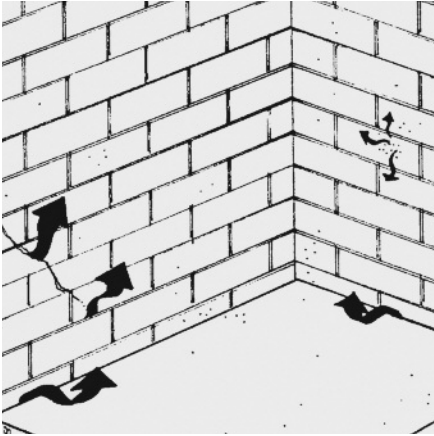

POINTS OF CLARIFICATION FOR THE RADON GUIDELINE

1. In addition to residential homes, the term “dwelling” in this guideline also applies to public buildings with a high occupancy rate by members of the public, such as schools, hospitals, long-term care residences, and correctional facilities. The following settings are excluded from this guideline:
 - a. Uranium mines, which are regulated by the Canadian Nuclear Safety Commission,
 - b. Other mines (e.g., fluorspar mines), which are regulated by provincial mining authorities,
 - c. Other workplaces, since exposures to radon at such locations are governed by existing guidelines for Naturally Occurring Radioactive Materials (NORM). Details are given in the Canadian Guidelines for Management of Naturally Occurring Radioactive Materials (NORM) and a copy may be viewed or downloaded at:
http://www.hc-sc.gc.ca/ewh-semt/pubs/contaminants/radiation/norm-mrn/index_e.html
2. The “normal occupancy area” refers to any part of the dwelling where a person is likely to spend several hours (greater than four) per day. This would include a finished basement with a family room, guest room, office or workshop. It would also include a basement apartment. It would exclude an unfinished basement, a crawl space, or any area that is normally closed off and accessed infrequently, e.g., a storage area, cold room, furnace room, or laundry room.

3. The aim is to remediate and reduce the radon concentration to less than 200 Bq/m³. If the radon concentration is found to be: greater than 600 Bq/m³, the remedial actions are recommended to be completed in less than a year; between 200 Bq/m³ and 600 Bq/m³, the remedial actions should be completed in less than two years.
4. “As low as practicable” refers to what can be achieved with conventional radon reduction methods in a cost-effective manner. This is consistent with the ALARA (As Low As Reasonably Achievable) principle, whereby reasonable efforts are made to maintain radiation exposures as low as possible, with social and economic factors taken into consideration. In most situations, a final level less than 200 Bq/m³ will be readily achievable. In a small number of cases, it may turn out that the application of all reasonable remediation techniques will still leave a residual radon level greater than 200 Bq/m³. It is not the intention of this guideline to impose excessive or unreasonable remediation costs in order to achieve a marginal increase in benefit. Such situations should be evaluated on a case-by-case basis.
5. This guideline was formally approved by the Federal Provincial Territorial Radiation Protection Committee in October 2006. The guideline is based upon current scientific understanding. It will be reviewed and updated as appropriate. Further information on radon may be obtained from the appropriate federal, provincial or territorial contact listed below or located at the following link: www.healthcanada.gc.ca/radon



Radon Contacts

Below is contact information about radon. Offices in your vicinity may have information specific to your geographic area.

Federal

Radiation Protection Bureau Health Canada

775 Brookfield Road
A/L 6302C
Ottawa, ON K1A 1C1
Tel: 613-954-6647
Fax: 613-952-9071

Canada Mortgage and Housing Corporation

700 Montreal Road
Ottawa, ON K1A 0P7
Tel: 1-800-668-2642
Fax: 613-748-2016

Regional Federal Contacts

Atlantic Region

E-mail: Radon_Atlantic@hc-sc.gc.ca

Telephone: 902-426-2038

Quebec Region

E-mail: Radon_Quebec@hc-sc.gc.ca

Telephone: 450-646-1353

Toll free: 1-800-561-3350

Ontario and Nunavut Regions

E-mail: Radon_Ontario@hc-sc.gc.ca

E-mail: Radon_Nunavut@hc-sc.gc.ca

Telephone: 416-973-4389

Toll free: 1-866-999-7612

Manitoba and Saskatchewan Regions

E-mail: Radon_MBKS @hc-sc.gc.ca

Telephone: 204-983-5490

Alberta and Northwest Territories Regions

E-mail: Radon_ABNT @hc-sc.gc.ca

Telephone: 780-495-2626

British Columbia and Yukon Regions

E-mail: Radon_BCYT @hc-sc.gc.ca

Telephone: 604-666-2083

Provincial and Territorial

Prince Edward Island



Environmental Health
16 Garfield Street
P.O. Box 2000
Tel: 902-368-4970
Fax: 902-368-6468

Newfoundland and Labrador



Department of Government Services
for Occupational Health and Safety
15 Dundee Avenue
Mount Pearl, NL A1N 4R6
Tel: 709-729-0218
Fax: 709-729-3445

New Brunswick



Office of the Chief Medical Officer of Health
P.O. Box 5100
Fredericton, NB E3B 5G8
Tel: 506-453-2280
Fax: 506-453-8702

Nova Scotia



Occupational Health and Safety Division
Department of Labour and Workforce Development
202-10 Webster Street
Kentville, NS B4N 1H7
Tel: 902-679-6326
Fax: 902-679-5166

Quebec 

Ministry of Health
1075 Ste-Foy Road, 12th Floor
Québec, QC G1S 2M1
Tel: 418-266-6765
Fax: 418-266-7510

Ontario 

Radiation Specialist
180 Queen Street West
Toronto, ON M5V 3L7
Tel: 416-973-4389 or 1-866-999-7612

Manitoba 

Medical Physics Division
675 McDermot Avenue
Winnipeg, MB R3E 0V9
Tel: 204-787-2212
Fax: 204-775-1684

Saskatchewan 

Radiation Safety Unit
Ministry of Advanced Education, Employment and Labour
400 - 1870 Albert Street
Regina, SK S4P 4W1
Tel: 306-787-4538
Fax: 306-787-2208

Alberta



Employment and Immigration
10808-99th Avenue, 8th Floor
Edmonton, AB T5K 0G5
Tel: 780-415-0612
Fax: 780-422-0014

British Columbia



Radiation Protection Services
655 West 12th Avenue (Main Floor)
Vancouver, BC V5Z 4R4
Tel: 604-707-2442
Fax: 604-707-2441

Yukon



Yukon Housing Corporation
410H Jarvis Street
Whitehorse, YT Y1A 2H5
Tel: 867-667-5759
Fax: 867-667-3664

Northwest Territories-Nunavut



Workers' Safety and Compensation Commission of NWT and Nunavut
P.O. Box 8888 Yellowknife, NT X1A 2R3
Tel: 1-800-661-0792
Fax: 867-873-0262

Workers' Safety and Compensation Commission
Iqaluit, Nunavut
Tel: 1-800-404-4407

Further Sources of Information

The Radiation Safety Institute of Canada is a non-governmental agency providing radiation safety programs and offering radon testing services:

Radiation Safety Institute of Canada
1120 Finch Avenue West
Suite 607
Toronto, ON
M3J 3H7
Tel: 416-650-9090 or 1-800-263-5803
E-mail: info@RadiationSafety.ca

The Environmental Protection Agency (EPA) is an agency of the United States Federal Government. For a list of, or to order radon-related EPA publications, contact:

IAQ INFO
P.O. Box 37133
Washington, DC
USA 20013-7133
Tel: 1-800-438-4318 or 703-356-4020
Fax: 703-356-5386
E-mail: iaqinfo@aol.com

NOTE – The opinions of the Radiation Safety Institute of Canada and the EPA may vary from the recommendations in this booklet.

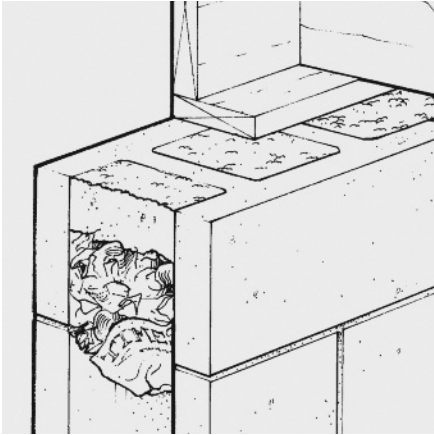

GLOSSARY

Dwelling

In the guideline, the term dwelling also applies to: personal residence, public buildings with a high occupancy rate by members of the public such as schools, hospitals, long-term care residences, and correctional facilities.

Becquerel

A unit used to measure radioactivity. Radon concentrations are measured in becquerels per cubic metre (Bq/m^3). One becquerel is described as one atom decaying per second.

